

PISTON CHECK VALVE FP800

CL800

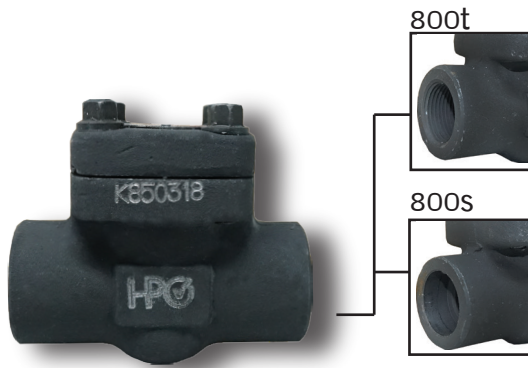

FORGED STEEL, bolted bonnet design to API602.
trim1.

Design construction:

API 602 - ASME B16.34 - BS 5352 Testing according to API 598

Socket Weld Ends to ASME B16.11

Screwed Ends (NPT) to ASME B1.20.1

Butt Welding Ends to ASME B16.25

Rating:

carbon steel class 800 1975 psig @ 100°F

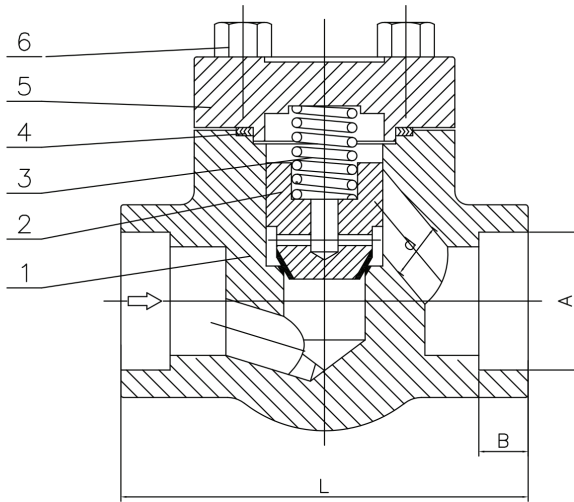

PARTS LIST

No.	Description	Material
1	body	A105+13Cr
2	disc	A182 F6a
3	spring	SS304
4	gasket	SS304+graphite
5	bonnet	A105
6	bolt	A193 B7

DIMENSIONS

Size	Inch	1/2"	3/4"	1"	1 1/4"	1 1/2"	2"
	DN	15	20	25	32	40	50
d		9	13	17.5	23	30	35
L		79	92	111	120	152	172
A		21.8	27.1	33.8	42.6	48.7	61.2
B		9.6	12.7	12.7	12.7	12.7	15.9